

TMB Presentation

TMB®

**Middle East Exclusive Agency
2021**

www.zjtmb.com

T
M
B



1



About TMB

- 1 **Company Overview**
- 2 **Competences**
- 3 **Application**

1.1 Company Overview

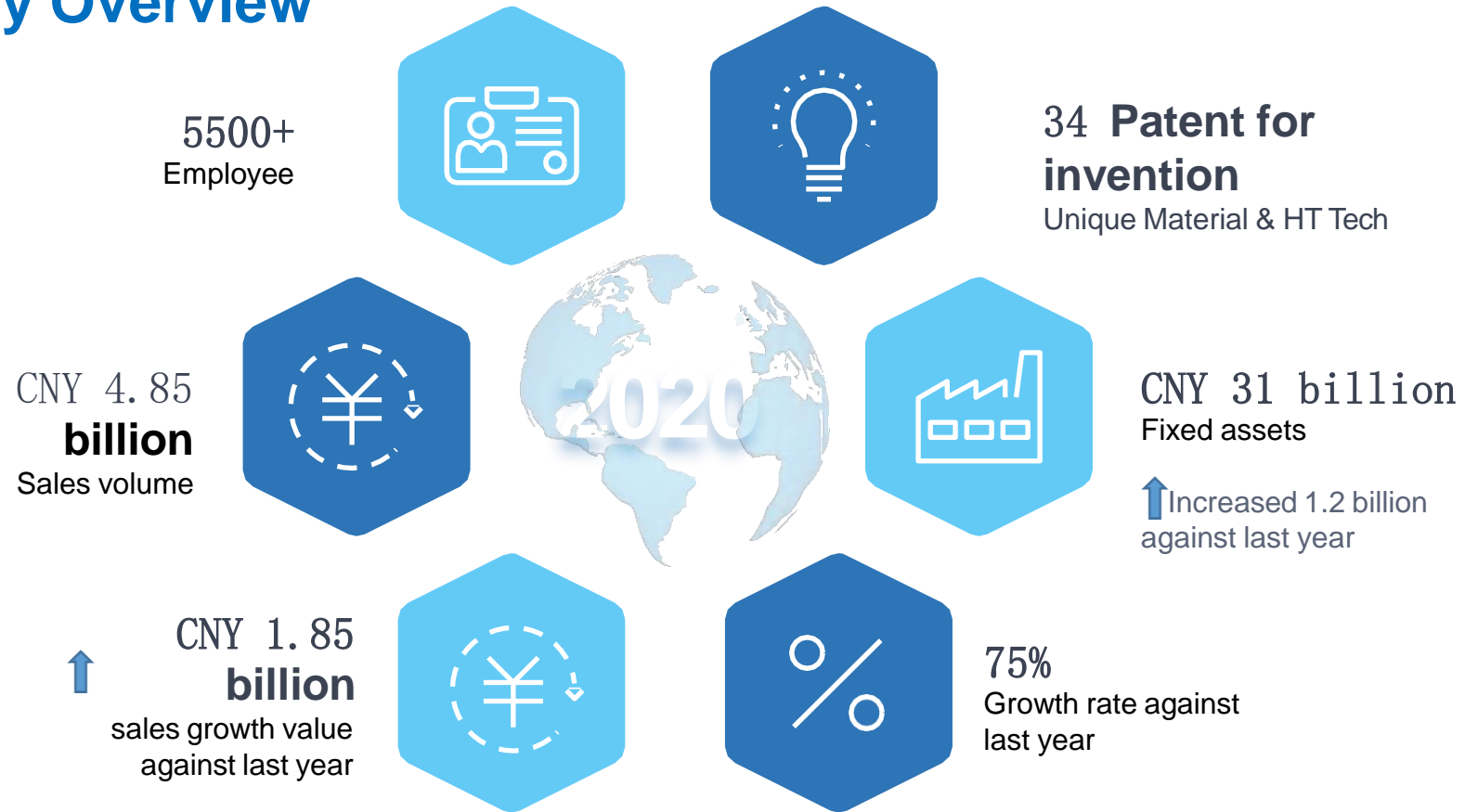

1.1 Company Overview-Sales by region

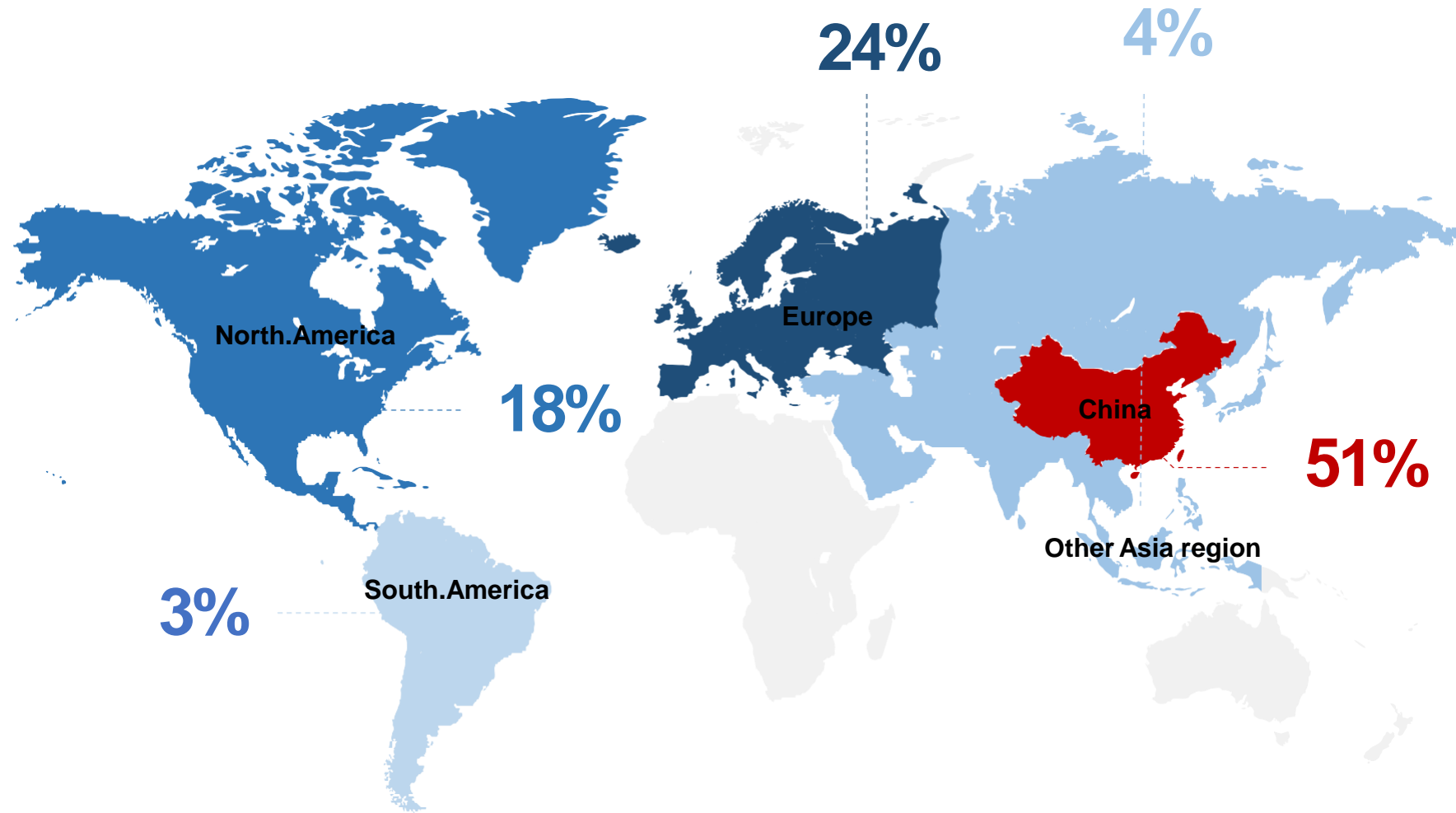

1.1 Company Overview-Locations



1.1 Company Overview-Application

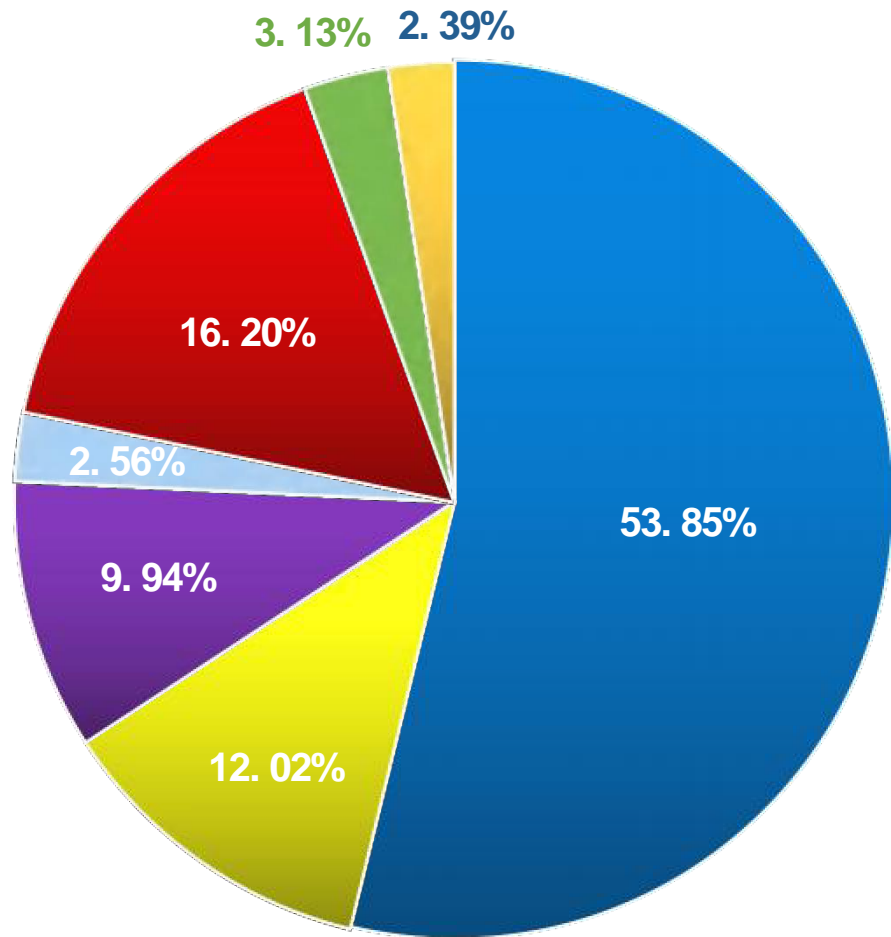

- Wind Turbine
- General Industry
- Rail Transit
- Automotive
- Off-highway Vehicle
- Metallurgy & Petroleum
- Aerospace





1.1 Company Overview—Company History

Unit:RMB



中国浙江省湖州市德清县雷甸镇运河路8号

No.8, Yunhe Road, Deqing Country, Huzhou City,
Zhejiang Province, China-313219



全系列产品

Full Range Of Products

TMB can manufacture more than 6000 items of product in 10 categories. With dimension of ID from minimum 5mm to OD maximum 12m. Among them, CRB, Railway bearings, wind power bearings have been obtained the biggest market share in China comparing with domestic competitors.

With the concept of customer-oriented and professional manufacturing level of long-life bearings, TMB has become a well-known and reliable business partner around the world.

TMB Products in a glance view

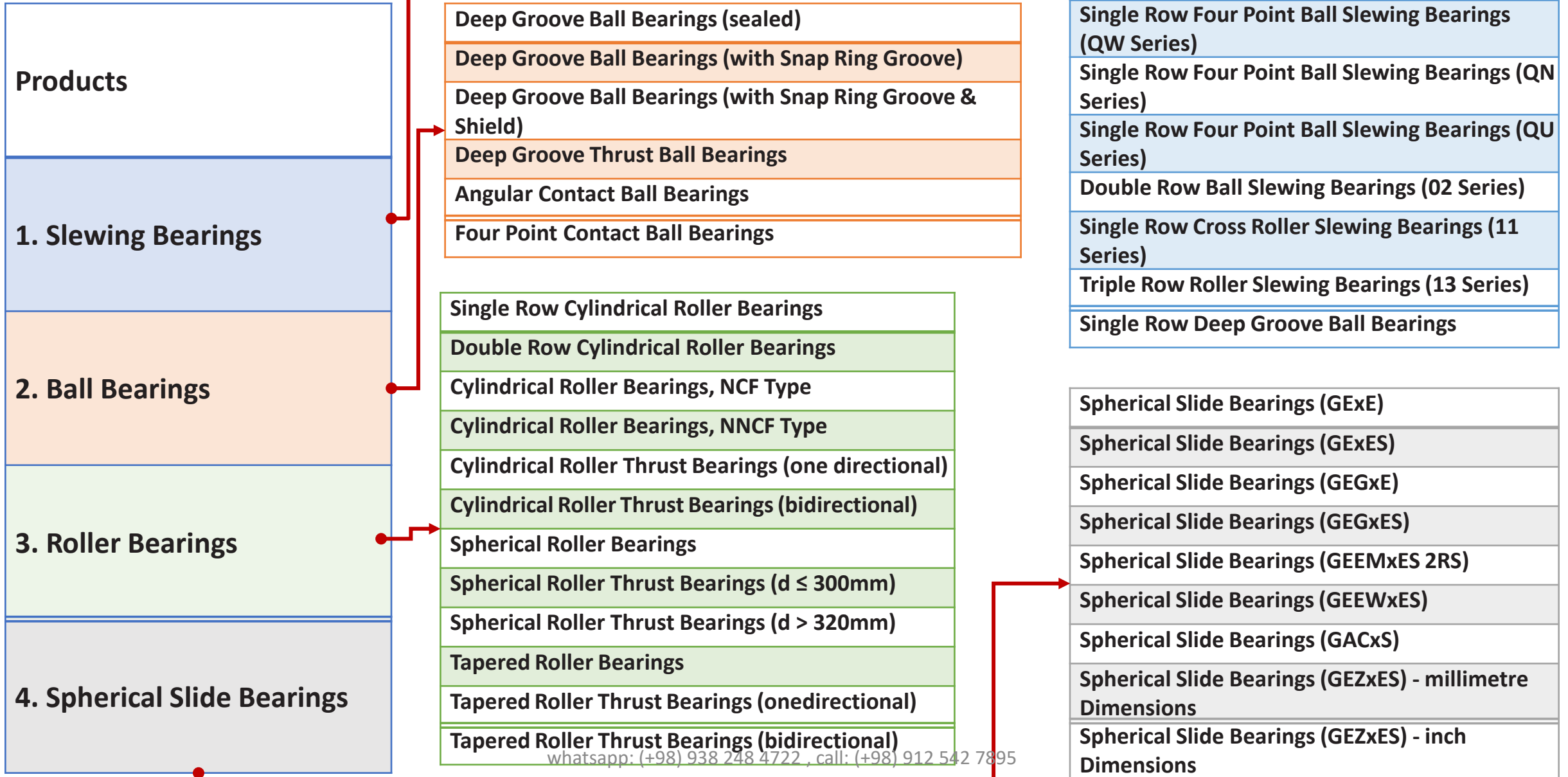



Quality



Efficiency



Experience

How do TMB control its quality ?

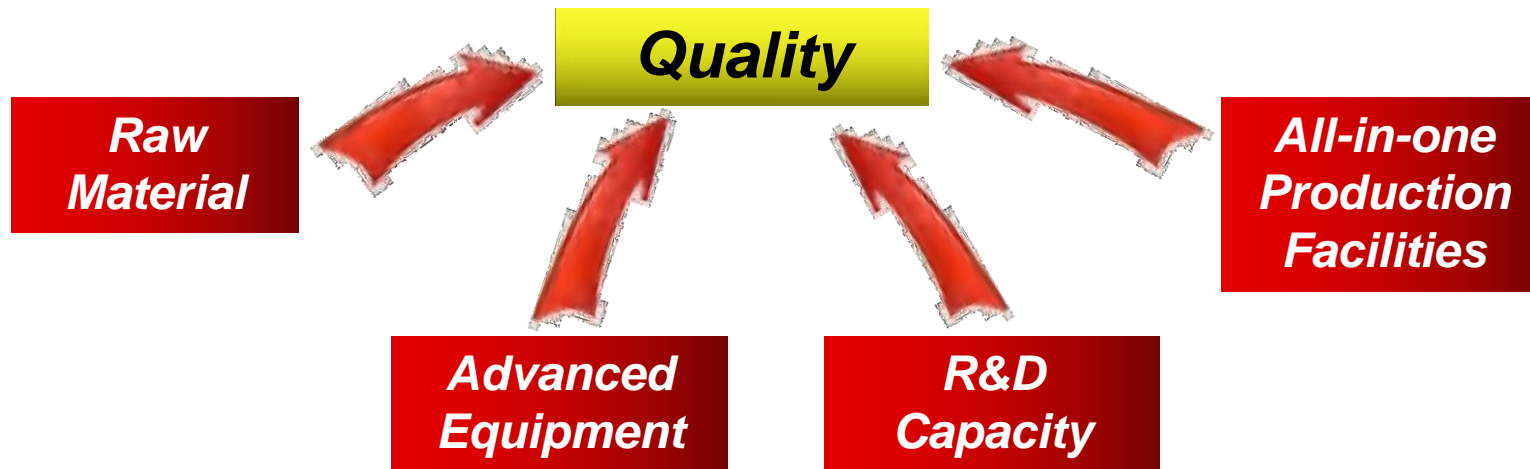

01 Raw Material



Ingot



Steel bar



42CrMo4A



**GCr15 Extra
High Quality
Steel**



**HDG High
Nitrogen Steel**

Steel Manufacturing Facilities



INTECO 60TEBT Electric Arc Furnace

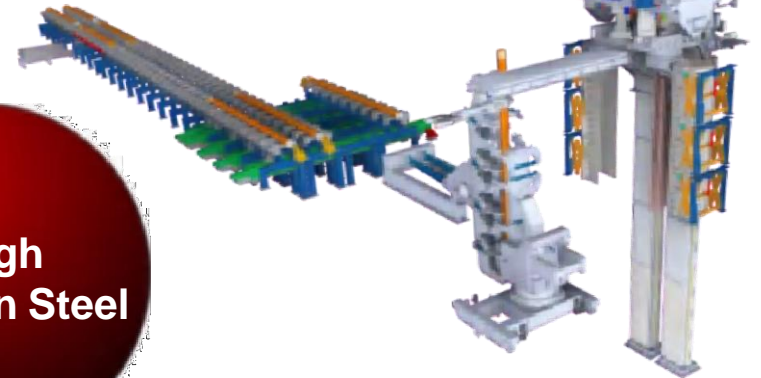

INTECO Section Casting Machine ALD Electric Slag Furnace



02 All-in-one Production Facilities

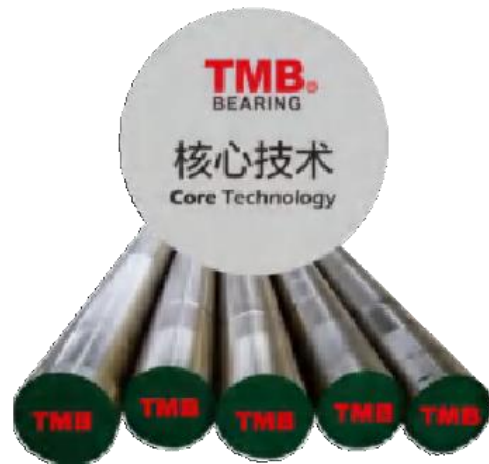

Material → Forging → Lathing → Heat treatment → Grinding → Assembly → Warehouse



TMB can manufacture more than 6000 items with different types of bearing. It has a full range of production line with annual capacity approximately 42mns pieces. Meanwhile, we offer an all-in-one service to our customers as well.

03 Advanced Equipment

Aichilin HT Line



Gas vacuum HT Line



Nagel Roller Micro-finishing Machine

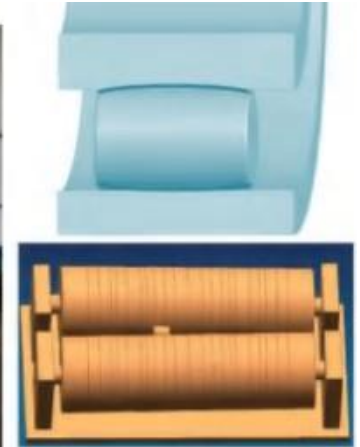

Using high level simulation process with crowned lapping roll, make sure the roller in logarithmic curve.

New HT technology- gas vacuum, Which imported from Poland and mainly Used for bearing with high-speed and Long lifetime.

04 R&D Capacity

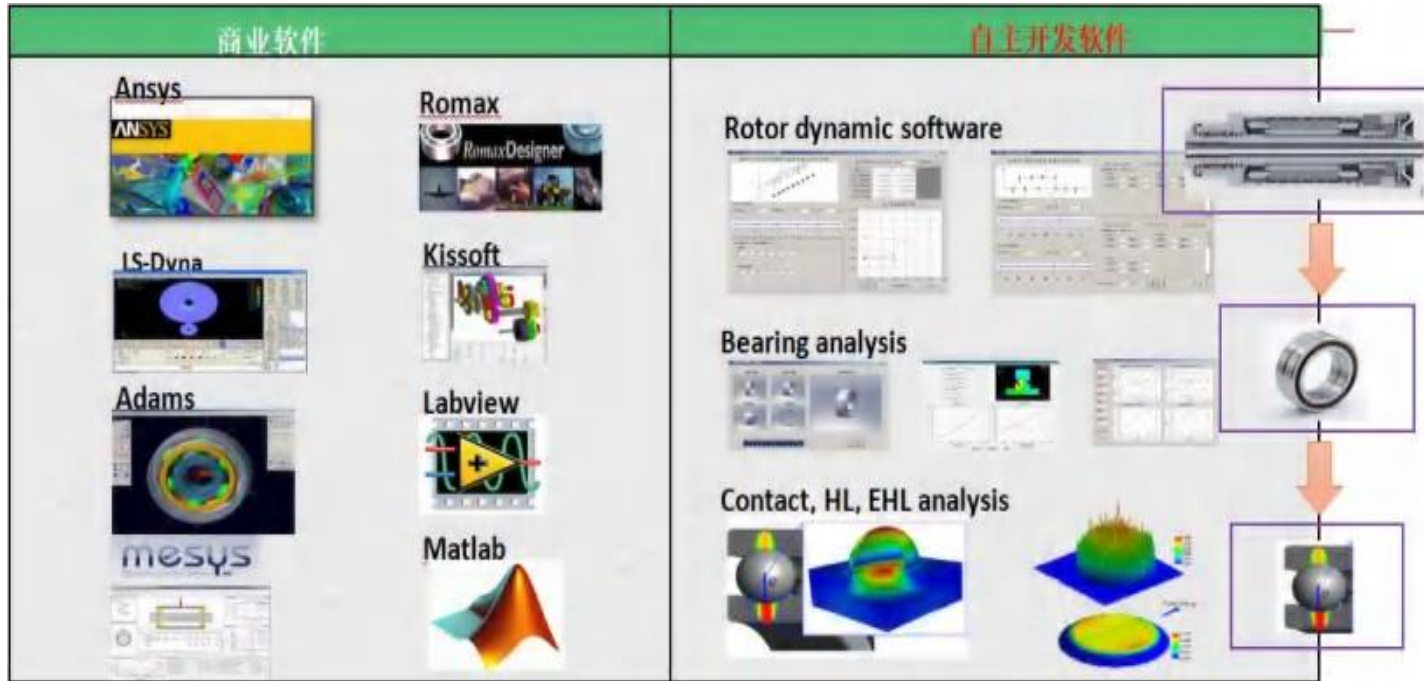

*Advantages: advanced design software like **Ansys**, **Romax** can make some stimulation test based on customer's real running condition of application and help to choose and verify the right type of bearing.*

Product design&verification Process

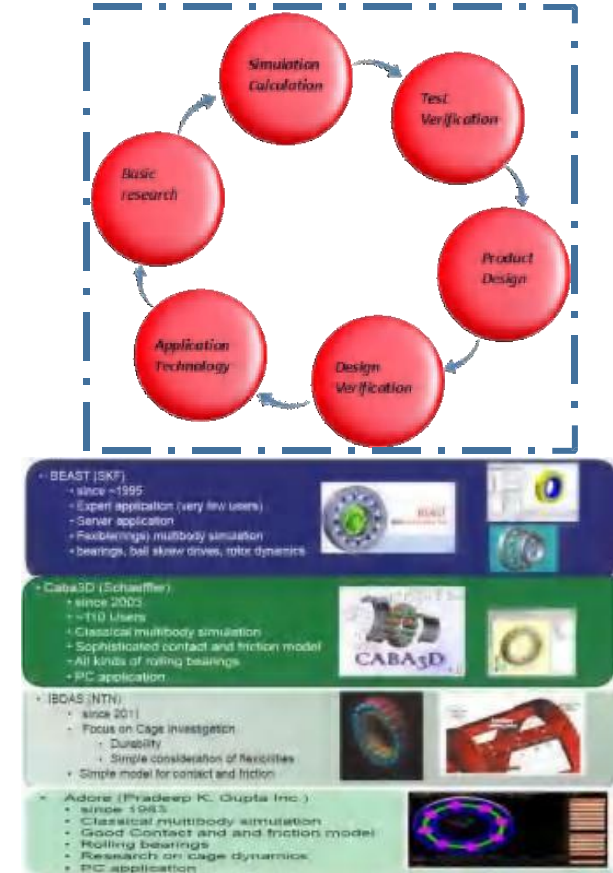

How can TMB improve its efficiency and keep competitive in market?

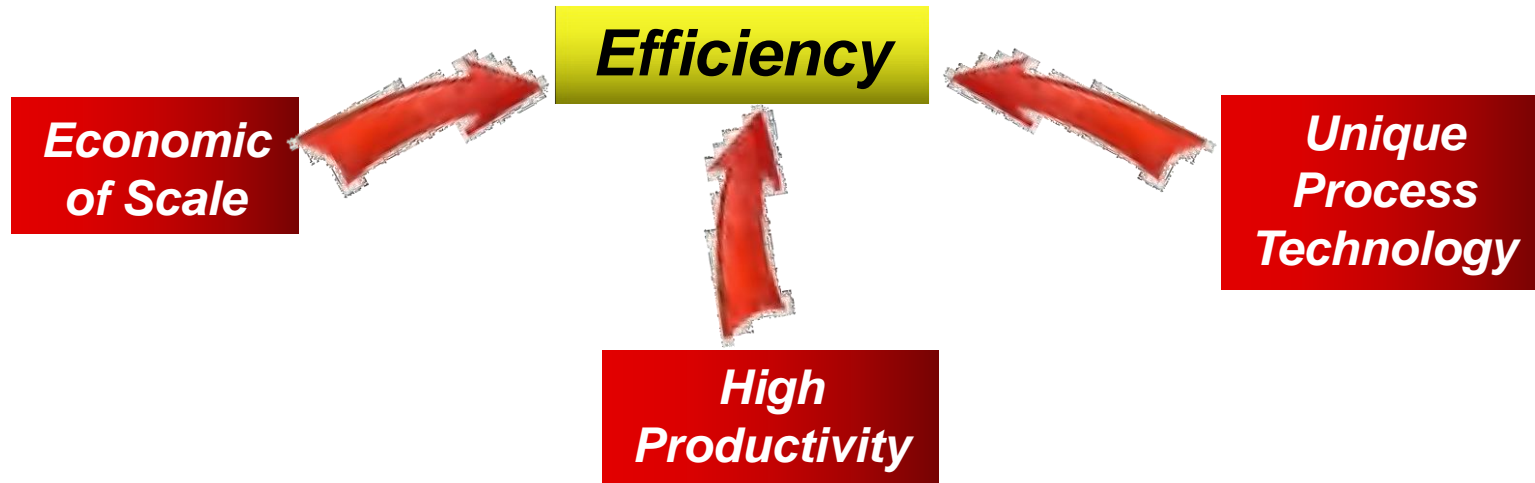

01 Economic of Scale

Product Type	Annual Productivity	Market Share	Sales Region	Rewards
Slewing bearing in Wind Turbine	20,000 pcs	TOP 1 TOP 3	Domestic Market Global Market	Leading brand
Railway bearing	450,000 pcs	TOP 2	China	Only one privated bearing manufactuer own the certificate for freight train and passenger train from CRRC
Construciton Machinery bearings	5Mns pcs	TOP 3	China	Leading brand
Aerospace bearing	300,000 pcs	TOP 1	China	One of the fourth bearing manufacturers own the certificate from China Military
Rolling mill bearing	200,000 pcs	TOP 1	China	

02 High Productivity



DGBB Auto grinding line

Grinding Production line	80
Annual capacity	50 mns pcs
Lead time on average	60 days



TRB Automatic grinding line



Intelligent assembly line

03 Unique Process Technology

Rings cold rolling process

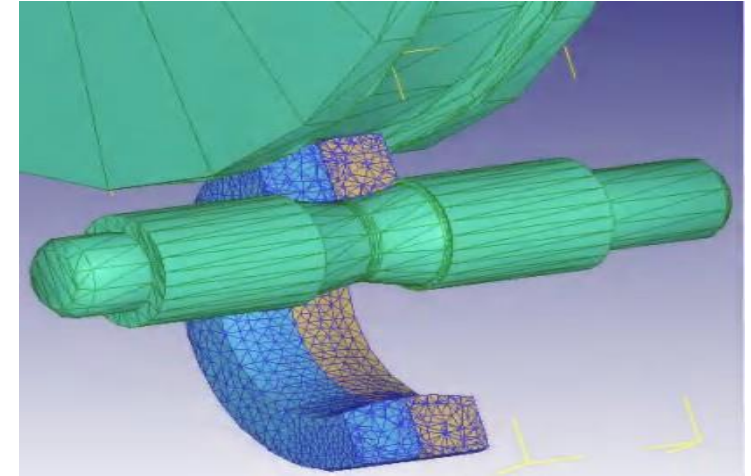
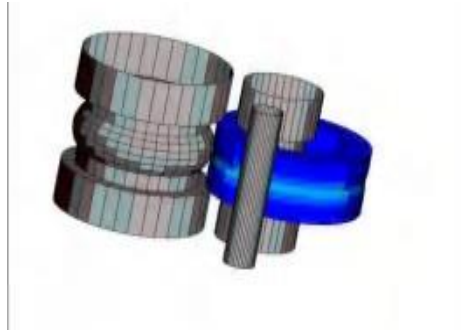
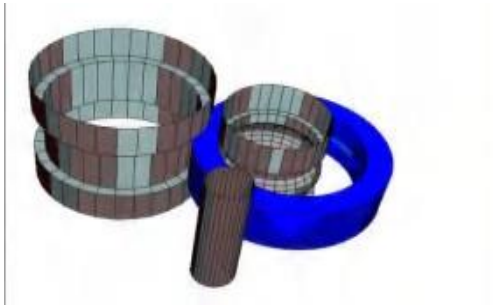

Where are TMB products used?

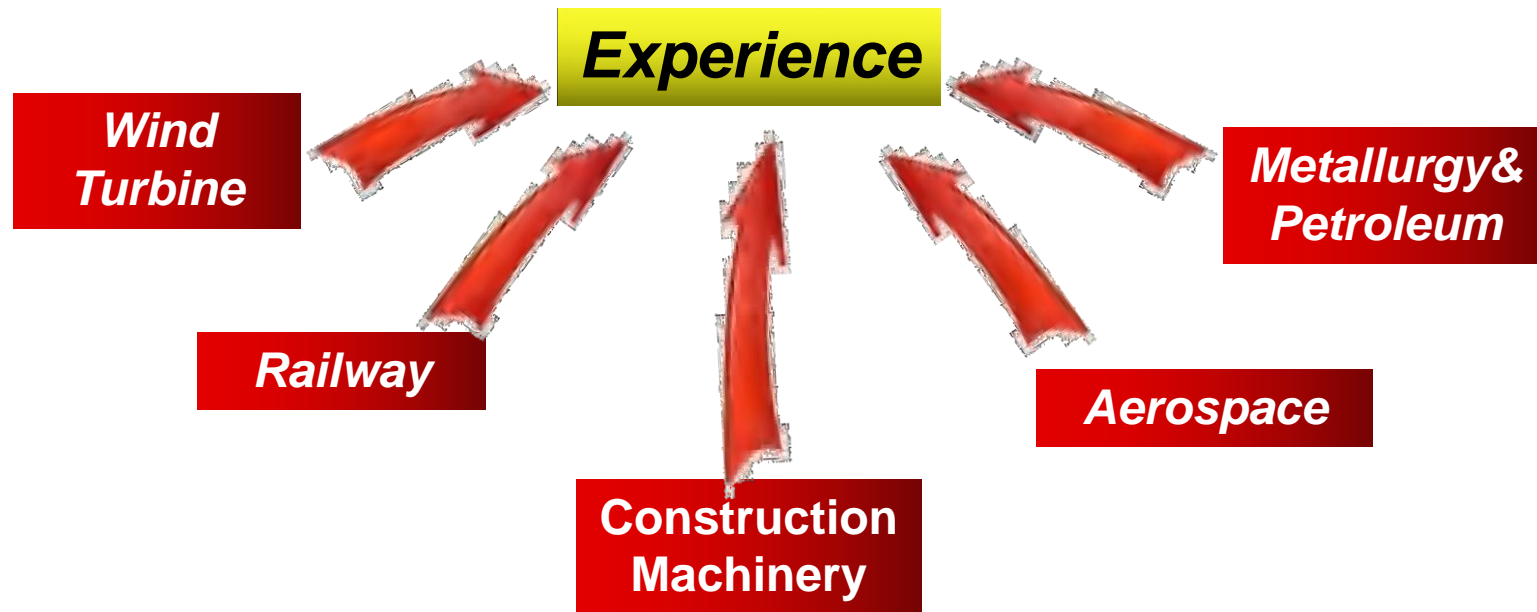

01 Wind Turbine



Products

Slewing bearings, tapered roller bearings, cylindrical roller bearings & deep groove ball bearings

Applications

TMB brand bearings is widely used in the field of wind turbine, such as slewing bearings in Yaw & pitch, TRB in reducer and CRB, DGBB in tension roller of wind turbine.



02 Freight & Passenger Train



Certificates: IRIS/CRCC

TMB is the only one private bearings manufacturer has China government's certificate for freight and passenger train.

Products

Tapered roller bearings, Cylindrical roller bearings, spherical roller bearings, angular contact ball bearings

Applications

Mainly used in the wheelset and gearbox of freight train and passenger train with speed below 120km/hr.



03 Metallurgy&Petroleum Industry



Products

4 Rows TRB/CRB, 2 Rows TRB/CRB, SRB, DGBB, ACBB



Applications

Hot/cold rolling machine in steel mill, oil extraction equipment



04 Aerospace



Applications *Aircraft engine*



Products

Deep groove ball bearings, angular contact ball bearings and cylindrical roller bearings are customized based on requirements.

The precision of bearings manufactured by TMB which applied in the field of military industry can reach to P2 level.



05 New energy vehicles

Products-Extra series

Cylindrical roller bearings
Deep groove ball bearings

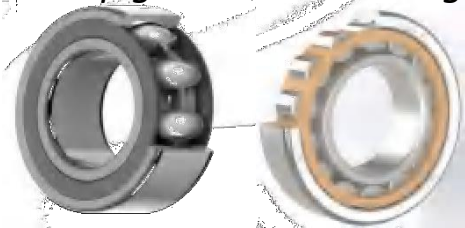

Applications

Gearbox, driven motor, axles
TMB Extra series bearings is designed for new energy car and adopted our new material & technology, it is verified that its lifetime is increased 3-6 times more than general ones, running speed can reach to 12000rpm. some of them has been already used in the gearbox and drive motor of new passenger & commercial vehicle.



Vehicle Type	Passenger Vehicle	Bus	Truck
Driven Motor			
Gearbox			

06 Commercial vehicles

Product: DGBB,CRB,TRB

Application: the gearbox of Heavy Truck,Medium Truck, Light Truck,Engineering vehicle,Bus,etc

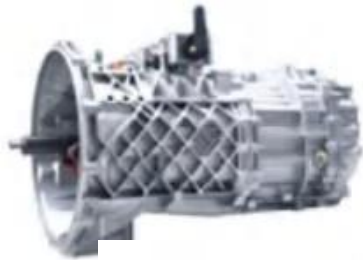



Products

deep groove ball bearings, cylindrical roller bearings, tapered roller bearings, angular contact ball bearings, thrust spherical roller bearings. Especially, bearings used in electric motor, TMB has the capacity to produce Z1VI-Z4V4 level with CM special clearance to meet customer's different requirements.

Applications

Electric motor, generator, reduction gears, marine gearbox, hoisting motor, compressor, etc.

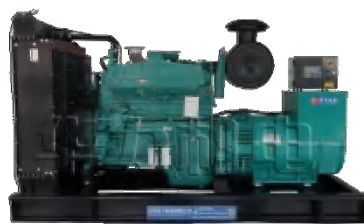

Construction Machines



Products

Angular contact ball bearings, spherical roller bearings, cylindrical roller bearings, slewing bearings, deep groove ball bearings, tapered roller bearings

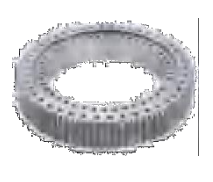

Application

gearbox, swing motor, travel motor, hydraulic motor & pump





Application Experience in Compressor

Application : Domestic & Commercial

Structure : Screw compressor 3-8P

Main product manufactured:

Part No.	Type
NU307E	CRB
6305	DGBB
NU2307E	CRB
E-NU307E	CRB
E-NU308ETVP7	CRB
TM6305	DGBB Ceramic
TM63/28	DGBB Ceramic



Advantages&advanced technology

TMB “Extra” Series bearing was mainly designed and researched based on the running conditions of compressor and new energy vehicles. it was made by using new material and technology, which verified its lifetime is three times as general bearings, the bearing's running speed can reach to 16000rpm as well. Among them, some types of bearing have already been applied in the field with the requirements of high running speed and high precision like passenger and commercial new energy vehicles, compressors.

中国浙江省湖州市德清县雷甸镇运河路8号

No.8, Yunhe Road, Deqing Country, Huzhou City,
Zhejiang Province, China-313219



Application Experience in Compressor

Application: Commercial Vehicle

Structure: Piston compressor,
Electric screw compressor

Main product manufactured:

Part No.	Type
K038571	DGBB Dobule Rows
235440	DGBB
5010831	DGBB

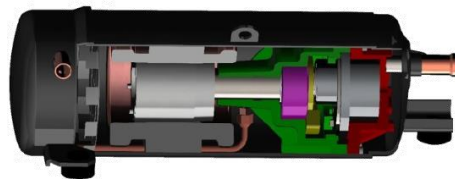

Wind Power	  海装风电	  MINGYANG ELECTRIC 明阳电气	 GOLDWIND  上海电气 SHANGHAI ELECTRIC	 SIEMENS Gamesa RENEWABLE ENERGY  运达风电 WINDEY	 DEC 东方电气 DONGFANG ELECTRIC
Rail	 中国中车 CRRC				
Construction	 CATERPILLAR®	 KOBELCO	 VOLVO	 Manitowoc	
	 HITACHI Inspire the Next	 WACKER NEUSON	 JAC MOTORS		
General	 CSIC	 Nabtesco	 Rexroth Bosch Group		





TMB[®]

THANK YOU

中国浙江省湖州市德清县雷甸镇运河路8号
No.8, Yunhe Road, Deqing Country, Huzhou City,
Zhejiang Province, China-313219